

NT1 5TH GENERATION

STUDIO CONDENSER MICROPHONE

10
10 YEAR
WARRANTY

DUAL CONNECT
XLR & USB
CONNECTIVITY

32
BIT
32 BIT FLOAT
DIGITAL OUTPUT

1" GOLD-SPUTTERED
CAPSULE

МУЗЦЕНТР
МУЗЫКАЛЬНОЕ ОБОРУДОВАНИЕ

<https://muzcentre.ru/>



The NT1 5th Generation fuses the classic sound signature of the legendary RØDE NT1 with cutting-edge, next-generation technology. It features RØDE's groundbreaking Dual Connect output, offering both XLR and USB connectivity for connecting to an audio interface, mixer or console, and other audio equipment, or directly to a computer for plug-and-play recording. It features a professional-grade audio interface built in, with RØDE's ultra-low-noise, high-gain Revolution Preamp™, high-resolution (up to 192kHz) A/D conversion, and advanced digital signal processing for recording pristine, studio-quality audio. It also features a 32-bit float digital output for recording everything from a whisper to the loudest drummer with no chance of clipping* and no need to set complex gain controls. These revolutionary features complement the warm silky character, extended frequency response, extremely low self-noise, and high SPL handling that the NT1 is renowned for, making the NT1 5th Generation the ultimate studio microphone for a wide variety of recording applications.

*up to the max SPL handling capability of the microphone

- Large-diaphragm (1-inch) gold-sputtered condenser capsule
- Extended frequency response
- Exceptionally low self-noise (4dBA)
- High sensitivity and high SPL handling
- Dual Connect output – XLR and USB connectivity
- Ultra-low-noise, high-gain Revolution Preamp™
- 32-bit float digital output
- High-resolution (192kHz) A/D conversion
- On-board DSP for advanced APHEX® audio processing, including a compressor, noise gate, high-pass filter, and Aural Exciter™ and Big Bottom™ effects
- Studio-grade shock mount and pop filter, XLR and USB cables included
- Available in black and silver
- Designed and made in RØDE's precision manufacturing facilities in Sydney, Australia

ACOUSTIC & ELECTRICAL SPECIFICATIONS

Acoustic Principle:	Pressure gradient
Active Electronics:	JFET impedance converter with bipolar output buffer
Capsule:	1.00"
Polar Pattern:	Cardioid
Address Type:	Side
Frequency Range:	20Hz - 20kHz
Output Impedance:	100Ω
Maximum SPL:	142 dB SPL
Equivalent Noise (A-Weighted):	4dBA
Sensitivity:	-32 dB re 1 Volt/Pascal (25 mV @ 94 dB SPL) +/- 2 dB @ 1 kHz
Analogue Power Requirements:	Via XLR: P48
Analogue Output Connection:	3-pin XLR

DIGITAL SPECIFICATIONS

Digital Power Requirements:	Via USB: 5V
Digital Output Connection:	USB-C
Bit Depth:	24-bit / 32-bit floating point
Sampling Rate (kHz):	48 / 96 / 192
Processing:	APHEX digital signal processing (only available at 48kHz sample rate)
Minimum OS Requirements:	Windows 10 Mac OS 10.15

NT1 5TH GENERATION

STUDIO CONDENSER MICROPHONE



10 YEAR WARRANTY



DUAL CONNECT XLR & USB CONNECTIVITY



32 BIT FLOAT DIGITAL OUTPUT



1" GOLD-SPUTTERED CAPSULE

Front view

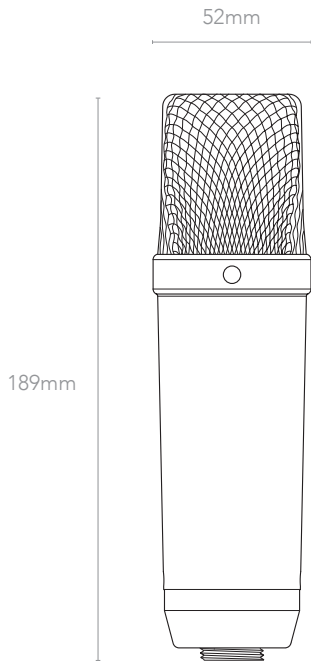

Bottom view

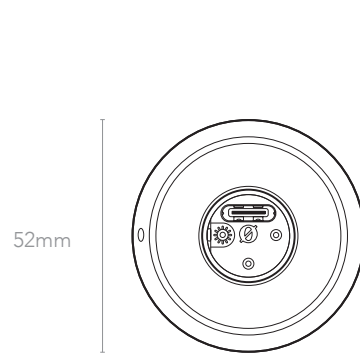

MECHANICAL SPECIFICATIONS

Weight (grams):	308
Dimensions (millimetres):	Length: 52 Width: 52 Height: 189
Included Accessories:	<ul style="list-style-type: none"> • SM6 Shock mount & pop filter • SC29 - 3m USB-C Cable • 6m XLR Cable • Dust Cover
RØDE Software Compatibility:	RØDE Central RØDE Connect RØDE UNIFY

POLAR PATTERN

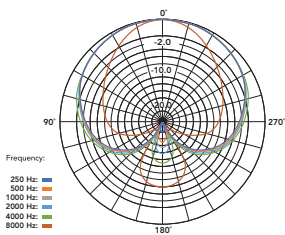

FREQUENCY RESPONSE

